



# MAKE THE STEEL RITE !

Toll Free:855-855-0399 Email:info@atosausa.com  
 www.atosa.com | www.atosausa.com  
 California,Colorado,Florida,Georgia, Illinois,Massachusetts,New Jersey,Ohio,Texas,  
 Washington

## Food Warmers

### Standard Features

7700

- ◆ Stainless steel structure
- ◆ Anti-drip well edge
- ◆ Lighted on/off switch
- ◆ Heat up within 10 minutes

AT51588  
 AT51388

- ◆ Hinged stainless lid for easy serving
- ◆ Removable stainless inset



AT51588



AT51388



7700

### Specifications

Model	Height	Diametr	Amps	Hertz	Voltage	Wattage	Capacity	Capacity per Compartment	Control Type	Inset Included	Number of Compartments	Temperature	Net Weight	Gross Weight
AT51588	14"	14.2"	3.3Amps	60	120 Volts	400 Watts	11 qt.	11 qt.	Infinite	Yes	1	105-195°F	10.93Lbs	13.14Lbs

Model	Height	Diametr	Interior Height	Interior Diameter	Amps	Hertz	Voltage	Capacity	Capacity per Compartment	Wattage	Control Type	Inset Included	Number of Compartments	Temperature	Net Weight	Gross Weight
AT51388	14"	14.2"	6 3/4"	10 1/2"	6.7 Amps	60	120 Volts	9 qt.	9 qt.	800 Watts	Infinite	Yes	1	105-195°	12.08Lbs	14.29Lbs

Model	Width	Depth	Height	Interior Width	Interior Depth	Interior Height	Amps	Hertz	Voltage	Wattage	Control Type	Material	Number of Wells	Temperature Settings	Net Weight	Gross Weight
7700	24"	14.6"	9"	12"	20"	6 1/2"	10Amps	60	120 Volts	1500 Watts	linfinite	Stainless Steel	1	Adjustable	16.27Lbs	18.47Lbs



**Plan View**

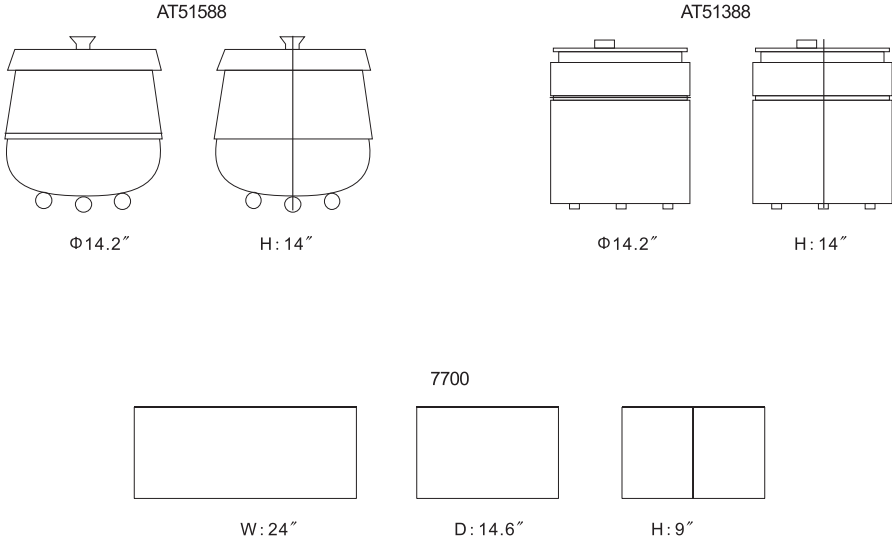

**Terms and Conditions**

**One Year Limited Warranty**

Atosa Catering Equipment warrants its equipment against defects in materials and workmanship, subject to the following conditions: Atosa Catering Equipment is warranted for one year, effective from the date of purchase by the original owner. A copy of the original receipt or other proof of purchase is required to obtain warranty coverage. This warranty applies to the original owner only, and is nontransferable. Should any product fail to function in its intended manner under normal use within the limits defined in this warranty, at Atosa's discretion, such product will be replaced with a new unit by Atosa, after defective unit has been inspected. And defect has been confirmed. Atosa does not assume any liability for extended delays in replacing any item beyond its control. This warranty does not apply to plastic and non-metallic synthetic parts that may need to be replaced due to normal usage, or lack of preventative maintenance.

**WHAT IS NOT COVERED BY THIS WARRANTY**

- Equipment that has not properly been maintained, damage from improper cleaning, and water damage to controls.
- Equipment that has not been used in an appropriate manner, or has been subject to misuse, neglect, abuse, accident, alteration, negligence, damage during transit, fire, flood, or acts of God.

If the equipment has been changed, altered, modified, or repaired without express written permission from Atosa, then the manufacturer shall not be liable for any damages to any person or to any property, which may result from the use of this equipment thereafter. For warranty and non-warranty related issues, technical support, purchase replacement parts contact Atosa toll free (855) 855-0399

\*In some cases, a 25% restocking fee may be charged to a buyer for returned items.